

Data subject to change without prior notice
Edition 12/2019 © 2019 JMG Cranes S.p.A. All rights reserved

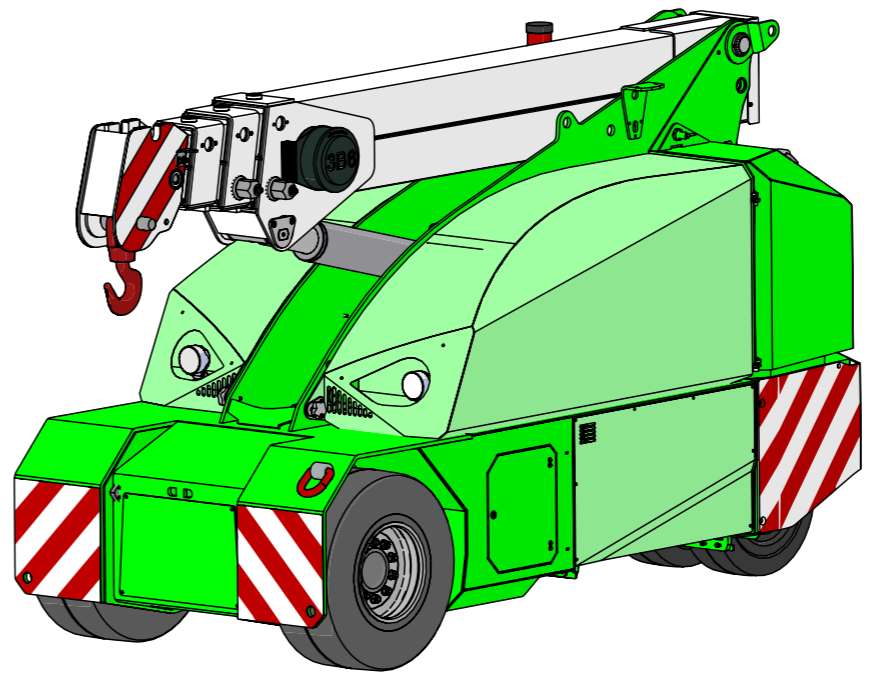

Electric Pick & Carry Cranes

JMG Cranes S.p.A.
Via Sito Nuovo 14
29010 Sarmato (PC) - Italy
t +39 0523 8486
e info@jmgcranes.com



MC 45S (metric)
Max Capacity 4,500 Kg

www.jmgcranes.com



MC 45S

RADIO-REMOTE CONTROL ON DRIVING, STEERING, BOOM MOVEMENTS, WINCH AND ACCESSORIES

FRONT-WHEELS DRIVE WITH COUNTER ROTATION

REMOVABLE COUNTERWEIGHTS

HYDRAULICALLY TELESCOPING SEQUENTIAL TYPE BOOM

Options :

- HYDRAULIC WINCH
- HYDRAULIC JIB WITH HYDRAULIC EXTENSION
- BENDABLE MANUAL JIB WITH MANUAL EXTENSION
- NON-MARKING TIRES
- HYDRAULIC FORKS
- MAN BUCKET
- ATEX CONVERSION
- CUSTOMIZED PAINTING



Technical features

Max Capacity kg	4,500
Dimensions mm	2772x1200x1648

Front-wheels drive. 2 electric motors AC 3 kW 48V Insulation class H	LMI Electronic safe load indicator and tilting moment limiter
Total Kg. 4,900 Removable counterweights Kg.1,360	Automatic braking system on all wheels
48 V - 640 Ah 8 working hours	Fabricated from preformed and welded quality steel plate
Front nr. 2 superelastic 23x10-12" Rear nr. 2 superelastic 18x7-8"	+60°-15°
Rear Steering angle -90°/+90°	Motor driven pump 9 kW - 48 V AC, Insulation class H

Load charts

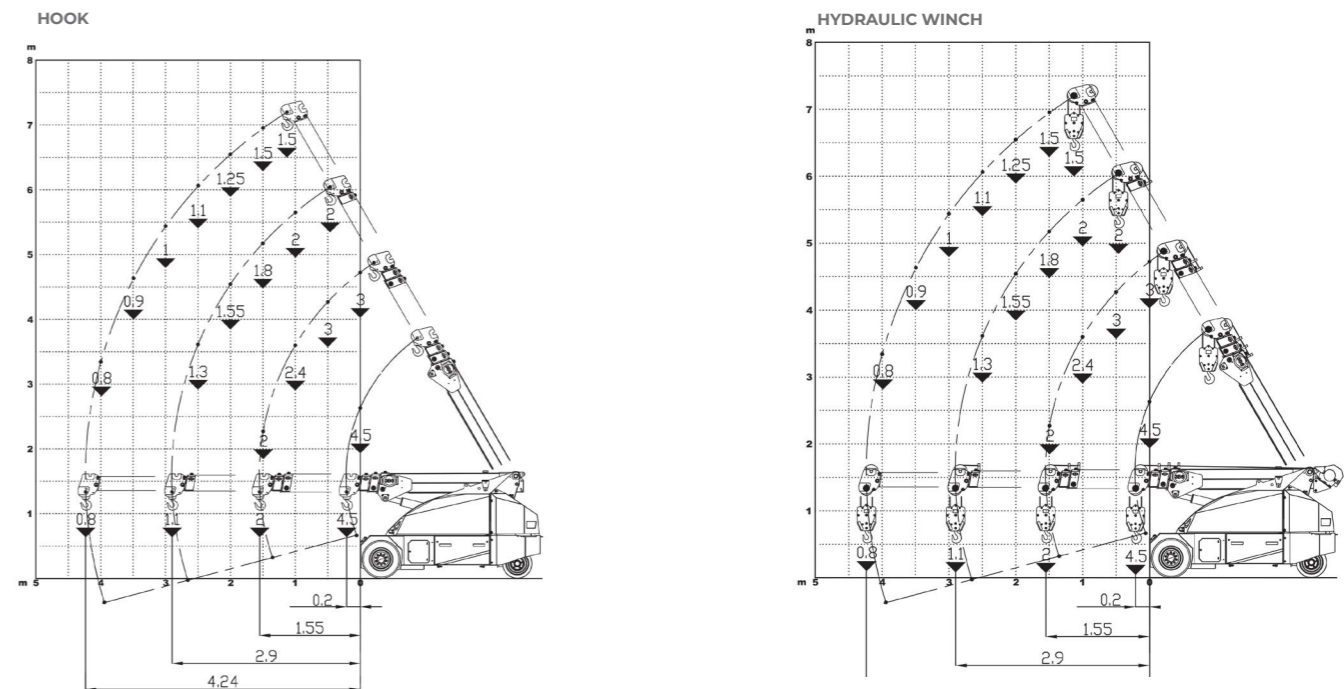

EU Standards CE

	UNI ISO 4030-1: A3
	2006/42 CE MD-2014/30 CE EMC - 2014/35 CE LVD - 2000/14 e and subsequent modifications
	EN 13000:2014 UNI ISO 4301-2:2011 and subsequent modifications

Dimensions

