

Data subject to change without prior notice  
Edition 12/2019 © 2019 JMG Cranes S.p.A. All rights reserved

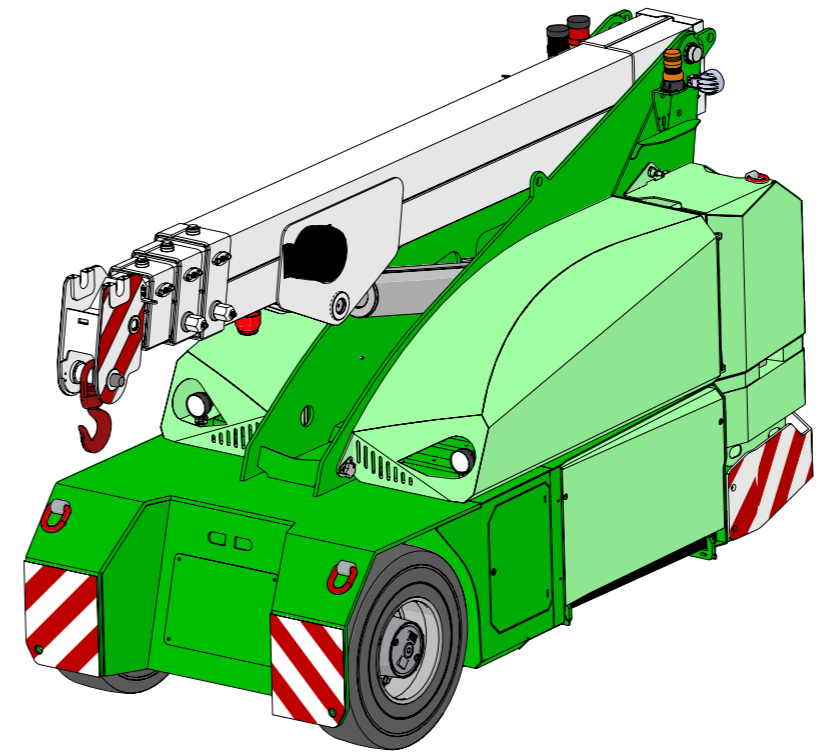

# Electric Pick & Carry Cranes

**JMG Cranes S.p.A.**  
Via Sito Nuovo 14  
29010 Sarmato (PC) - Italy  
t +39 0523 8486  
e info@jmgcranes.com



**MC 60S (metric)**  
Max Capacity 6,000 Kg

[www.jmgcranes.com](http://www.jmgcranes.com)



# MC 60S

RADIO-REMOTE CONTROL ON DRIVING, STEERING, BOOM MOVEMENTS, WINCH AND ACCESSORIES

FRONT-WHEELS DRIVE WITH COUNTER ROTATION

REMOVABLE COUNTERWEIGHTS

HYDRAULICALLY TELESCOPING SEQUENTIAL TYPE BOOM

### Options :

- HYDRAULIC WINCH
- HYDRAULIC JIB WITH HYDRAULIC EXTENSION
- BENDABLE MANUAL JIB WITH MANUAL EXTENSION
- NON-MARKING TIRES
- HYDRAULIC FORKS
- MAN BUCKET
- ATEX CONVERSION
- CUSTOMIZED PAINTING



## Technical features

Max Capacity kg	6,000	Front-wheels drive. 2 electric motors AC 3,5 kW 72V Insulation class H	<b>LMI</b> Electronic safe load indicator and tilting moment limiter
	Dimensions mm	Total Kg. 6,700 Removable counterweights Kg.1,900	Automatic braking system on all wheels
Dimensions mm		72 V - 640 Ah 8 working hours	Fabricated from preformed and welded quality steel plate
	Dimensions mm	Front nr. 2 superelastic 250-15" Rear nr. 2 superelastic 21x8-9"	+60°-15°
Dimensions mm		Rear Steering angle -90°/+90°	Motor driven pump 12 kW - 72 V AC, Insulation class H



## Load charts

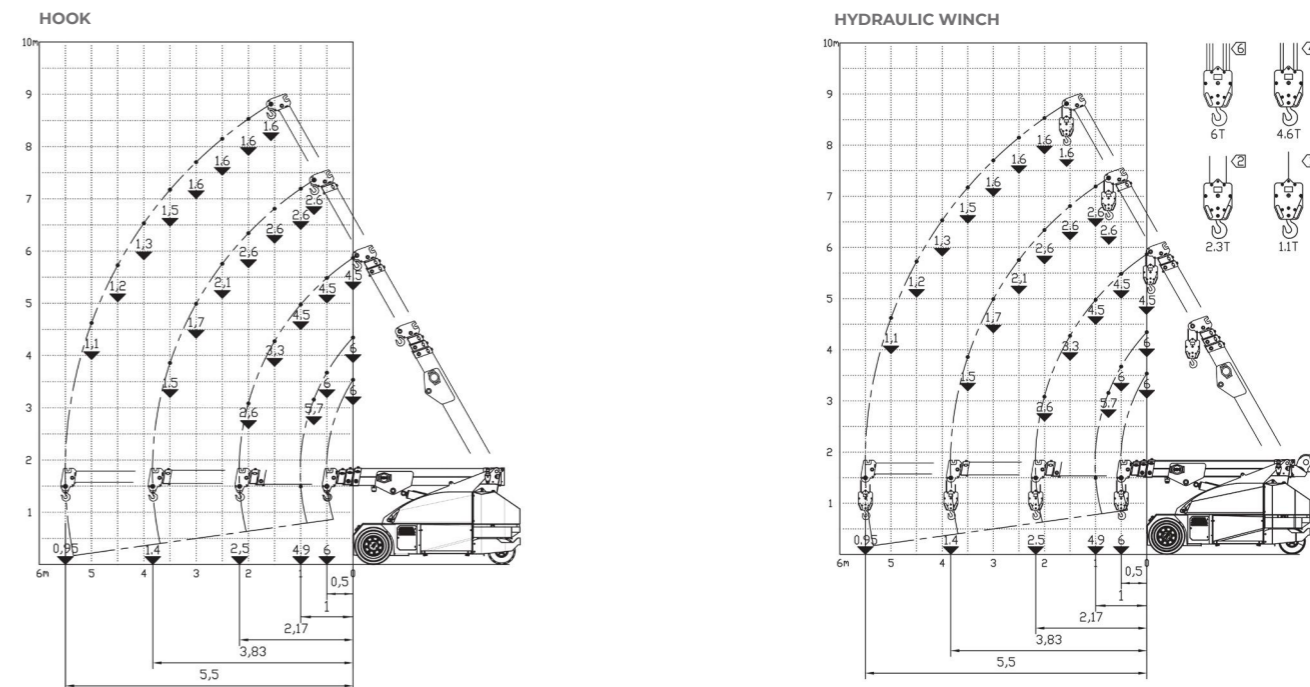

## EU Standards CE

	UNI ISO 4030-1: A3
	2006/42 CE MD-2014/30 CE EMC - 2014/35 CE LVD - 2000/14 e and subsequent modifications
	EN 13000:2014 UNI ISO 4301-2:2011 and subsequent modifications



## Dimensions

